

# INSTRUCTION MANUAL

## G-5400B / G-5600B

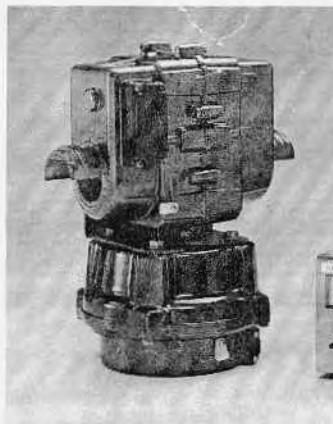

Please check [www.aa4df.com](http://www.aa4df.com) for other paper, PDF, and/or downloadable test eqpt, ham & comm'l radio/electronics related manuals and equipment for sale or trade.



YAESU MUSEN CO., LTD.  
C.P.O. BOX 1500  
TOKYO, JAPAN

From The N3UJJ.COM Document Library

YAESU G-5400 & G-5600  
ANTENNA AZIMUTH-ELEVATION ROTATORS & CONTROLLER

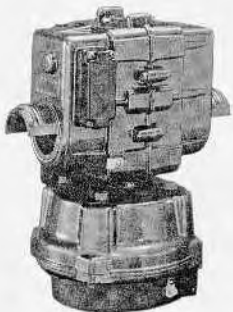
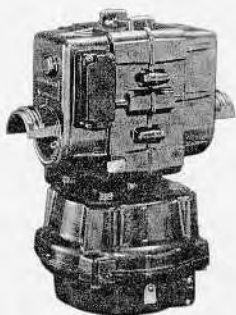

The Yaesu G-5400 and G-5600 provide 360° azimuth and 180° elevation control of medium- and large-size unidirectional satellite antenna arrays under remote control from the station operating position. The two factory-lubricated rotator units are housed in weatherproof melamine resin coated die-cast aluminum, to provide maintenance-free operation under all climatic conditions. Each rotator contains a thermal sensor to prevent damage from overheating during periods of high usage. The rotators may be mounted together on a mast, or independently with the azimuth rotator inside a tower and the elevation rotator on the mast.

The controller unit is a handsomely-styled desktop unit with dual meters and direction controls for azimuth, in compass direction and degrees; and elevation, from 0° to 180°. An External Control jack is provided on the rear of the controller for interfacing via D-to-A converters to an external microcomputer or other display/controller.

Please read this manual carefully before installing the rotators.

## SPECIFICATIONS

### Voltage requirement:

110-120 or 200-240 VAC

### Motor voltage:

24 VAC

### Rotation time (approx., @60Hz):

Elevation (180°): 58 sec.

Azimuth (360°): 5400B: 53 sec.

5600B: 50 sec.

### Maximum continuous operation:

5 minutes

### Rotation torque:

Elev.: 14 kg-m (101 ft-lbs)

G-5400 Azim.: 6 kg-m (44 ft-lbs)

G-5600 Azim.: 7 kg-m (51 ft-lbs)

### Braking torque:

Elev.: 40 kg-m (289 ft-lbs)

G-5400 Azim.: 20 kg-m (145 ft-lbs)

G-5600 Azim.: 40 kg-m (289 ft-lbs)

### Vertical load:

200 kg (440 lbs)

### Pointing accuracy:

±4 percent

### Wind surface area:

0.8 m<sup>2</sup>

### Control cables:

2 x 6 conductors - #20 AWG or larger

### Mast diameter:

38-63mm (1-½ to 2-½ inches)

### Boom diameter:

32-43mm (1-¼ to 1-5/8 inches)

### Weight:

Rotators: 9 kg (20 lbs)

Controller: 3 kg (6.6 lbs)

## UNPACKING & INSPECTION

When unpacking the rotator confirm the presence of the following items:

|                    |    |
|--------------------|----|
| Rotator Unit       | 1  |
| Controller Unit    | 1  |
| Mast Clamp (pair)  | 1  |
| L-Bracket          | 1  |
| M8x16 Hex bolt     | 4  |
| M8x25 Hex bolt     | 4  |
| M8x70 Hex bolt     | 4  |
| 8mm Split washer   | 20 |
| 8mm Nut            | 8  |
| 8mm Flat washer    | 4  |
| 8mm dia Stud bolt  | 4  |
| U-Bolt             | 2  |
| 6mm Flat washer    | 4  |
| 6mm Split washer   | 4  |
| 6mm Nut            | 4  |
| 6-pin DIN plug     | 1  |
| Spare Fuse         | 1  |
| (117V:2A, 220V:1A) |    |

If any of these items are missing or appear to be damaged, save the carton and packing material and notify the shipping company (or dealer, if purchased directly at his shop).

Before proceeding with installation, confirm that the AC voltage label on the rear of the Controller matches your local line voltage: either "117V" for 110 to 120 VAC, or "220" for 220 to 240 VAC. If the labelled voltage range does not match, return the controller to the dealer from whom you purchased it (different power transformers are installed for the different voltage ranges).

Note that cable is not included with the rotator, as the length must be determined case-by-case. Contact your Yaesu dealer to obtain the length of cable your installation requires. For runs of over 100 feet, use #18 AWG instead of #20 AWG.

## CONTROL CABLE PREPARATION & CONNECTION

Before installing the antenna and rotators, make all connections and test rotator operation thoroughly on the ground as described below.

Your control cables should have six conductors each of at least #20 AWG gauge (if less than 100 feet long).

- (1) Remove the terminal covers from the rotators and controller, and push one end of each cable through the grommets in the rotator terminal covers about 2 cm.
- (2) Using special care to avoid nicking the insulation of the individual wires, strip back about 50mm of the outer jacket of the cables from each end, and then strip 15mm of insulation from each wire.
- (3) Twist the strands of each wire, and form each into a hook large enough to encircle the terminal screws on the rotators and controller. Then lightly tin each hook with solder (both ends of each cable should be prepared in the same way).
- (4) Connect each wire to a terminal, numbers 1 - 6, on the rotators (terminals 7 and 8 are not used). Note the color of the wire at each terminal.
- (5) Referring to your notes of the wire color at each terminal on the rotators, connect the wires to the terminals on the controller so that the wire from each terminal on the rotators connects to the terminal with the same number on the controller, ie., 1 to 1, 2 to 2, etc.
- (6) On the controller, make sure that the POWER switch is in the OFF position, and connect the line cord to the AC power outlet.
- (7) Turn on the POWER switch. The meter lamps should light and the meters indicate to the center of their scales (90° on the ELEVATION meter scale, and 0° on the AZIMUTH scale).
- (8) Press the UP switch. The ELEVATION rotator should turn as the meter indication moves to the right. Release the UP switch and confirm that the rotator slowly stops.
- (9) Repeat step 8, pressing the DOWN switch instead of UP. The ELEVATION rotator should turn in the opposite direction as the meter indication moves to the left.
- (10) If operation does not occur as described above, check for a wiring error in the elevation cable connections.
- (11) Press the LEFT switch. The AZIMUTH rotator should turn counterclockwise as the meter indication left moves to the left. Release the LEFT switch and confirm that the rotator slowly stops.
- (12) Repeat step 11, pressing the RIGHT switch instead of the LEFT switch. The AZIMUTH rotator should turn clockwise as the meter indication moves to the right.
- (13) If operation does not occur as described in steps 11 and 12, check for a wiring error in the azimuth cable connections.

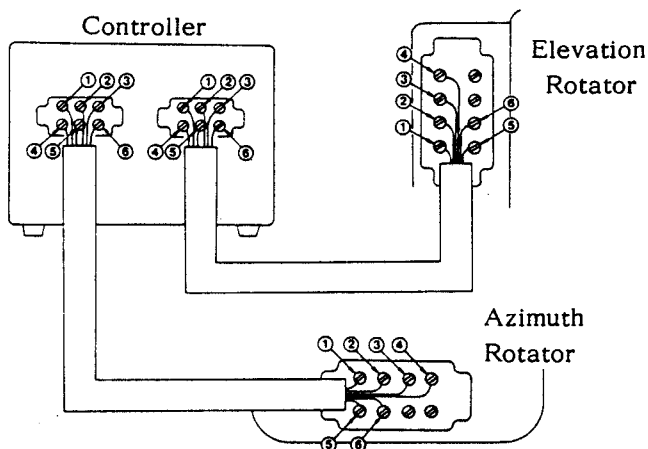

When everything checks out in the above steps, slide the terminal covers over the rotator terminal boxes, and screw them tightly into place. Then remove the cable clamps from the rotators, clip them over

the cables, and screw them back onto the rotators, leaving a little slack between each clamp and terminal cover. Do the same with the cable clamps on the back of the controller, and replace the two controller terminal covers.

## PRE-INSTALLATION ADJUSTMENT

Switch the controller off and adjust the 0 ADJ screws beneath each meter face, if necessary, so that each meter points to the left edge of the scale. Then turn the controller back on for the following steps.

### Azimuth Indicator

Press and hold the LEFT switch and allow the azimuth rotator to turn until it reaches its end stop. Note the precise position of the rotator (mark the housing, if necessary), and then press and hold the RIGHT switch to bring the rotator around one full turn to exactly the same position. The meter should now point precisely to 180° at the right edge of the scale. If not, adjust the FULL SCALE potentiometer at the upper corner of the rear panel above the AZIMUTH terminals.

### Elevation Indicator

Press the UP switch to align the 180° markers on the rotator. The meter should now point precisely to 180° at the right end of the scale. If not, adjust the FULL SCALE potentiometer at the upper corner of the rear panel above the ELEVATION terminals.

### Notes on Controller Operation:

If both UP and DOWN switches or RIGHT and LEFT switches are pressed at the same time the corresponding rotator turns up or right (clockwise).

Release the switch when the meter indicates in the end zones (the rotator stops).

Remember to turn the controller off when the rotators are not in use.

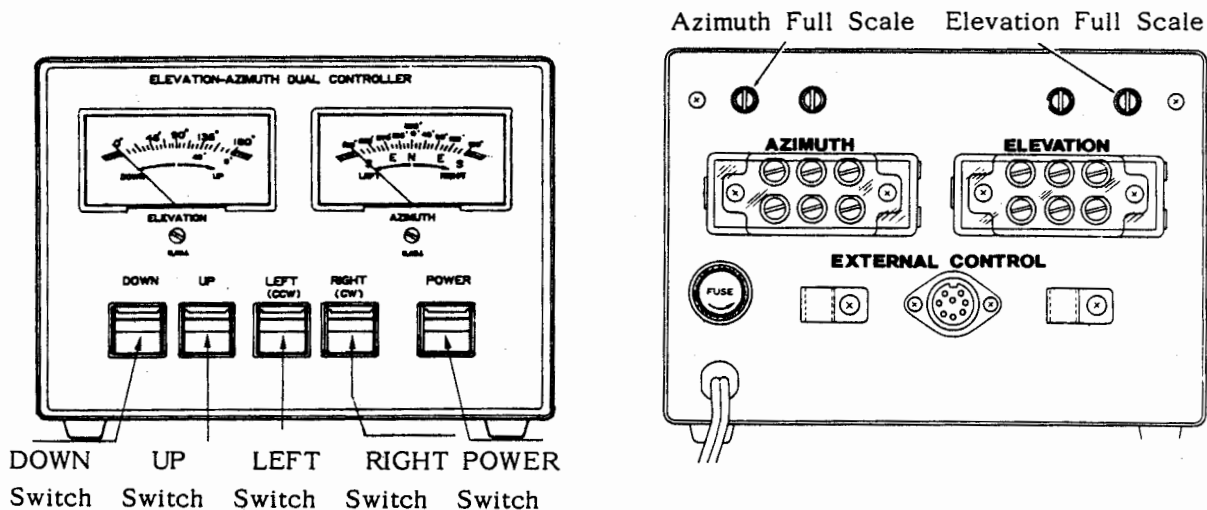

## ROTATOR INSTALLATION

The G-5400 is designed to accommodate medium-size antenna arrays, while the G-5600 can accommodate larger arrays. The maximum safe load depends on the physical size of the antenna, method and quality of mechanical installation, and maximum wind velocity at the installation site.

The diagrams at top of the next page show several recommended installations. Notice that the preferred mounting method requires that each antenna be attached to the boom at its center of gravity, with the boom then attached to the elevation rotator at its center of gravity. This minimizes stress on the rotator and supporting structure, especially during strong winds.

The azimuth rotator may be mounted at the top of the mast together with the elevation rotator, or separately inside of a supporting tower. The latter method is generally stronger, and preferable in high wind locations or for large antennas, but requires some additional hardware not supplied with the G-5400 and G-5600 kits.

### Mounting the Rotators Together

NOTE: If the elevation rotator is to be mounted on the mast alone, skip this section and see "Mounting the Rotators Separately".

- (1) Referring to Figure 1a, bolt the L-bracket to the top of the azimuth rotator using four M8x16 bolts and split washers.
- (2) Slip a split washer over one end of each stud bolt (x4), and screw the stud bolts firmly into holes in the side of the elevation rotator.
- (3) Insert the stud bolts through the remaining holes in the L-bracket, and secure them with four nuts and split washers.

### Mounting the Rotators Separately

Only do this if the elevation rotator is to be mounted alone on the mast. You will need four long stud bolts and four additional pipe clamps (available from your dealer).

- (1) Slip a split washer over the short-thread end of each stud bolt (x4), and screw the stud bolts firmly into holes in the side of the elevation rotator.
- (2) Slip an 8mm flat washer over each installed stud bolt, and then the pipe clamps, as shown in Figure 1b. Place another flat washer and then a split washer over the end of each stud bolt, and start a nut on each to hold the hardware in place.

### Installing the boom in the Elevation Rotator

Do these steps for all installations.

- (1) Slide the boom through the rotator.
- (2) Place one U-bolt over each arm of the rotator, and assemble one pipe clamp, flat washers, split washers and nuts on the U-bolts as shown in Figure 2. Center the boom carefully, and alternately tighten the nuts on each U-bolt  $\frac{1}{2}$ -turn beyond the point where the split washers are flattened.

Be sure to leave enough slack in both the elevation control cable and the coaxial cable feedline around the azimuth rotator so the antenna can rotate 360° without straining the cable or feedline.

For dual parallel arrays, feedlines should be taped to the boom on either side of the rotator, with enough slack left to allow 180° rotation without stressing the feedlines.

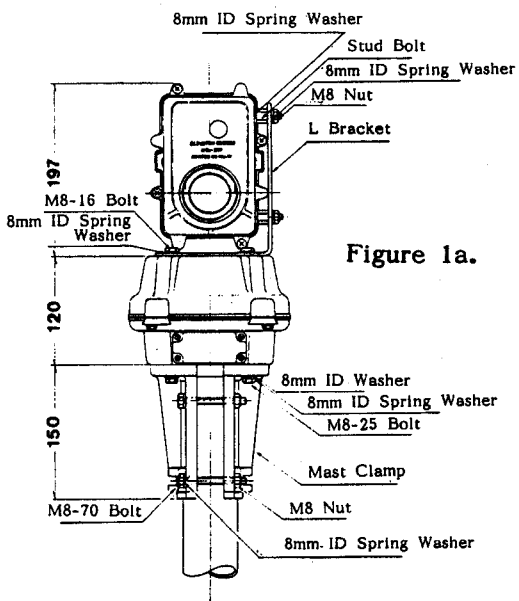
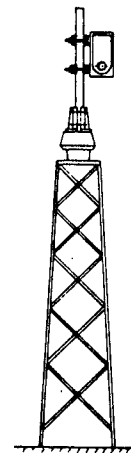
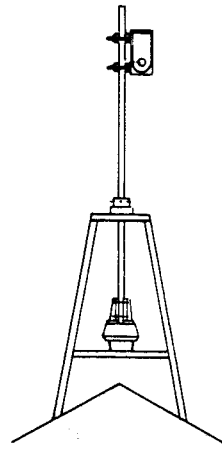
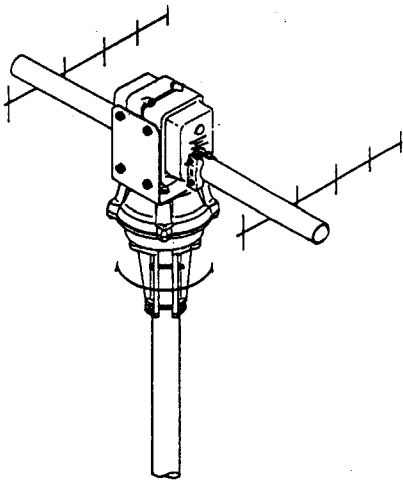

Figure 1a.

| NO | QTY | DESCRIPTION            |
|----|-----|------------------------|
| 1  | 8   | 8 $\phi$ SPRING WASHER |
| 2  | 8   | 8 $\phi$ NUT           |
| 3  | 8   | 8 $\phi$ WASHER        |
| 4  | 4   | 8 $\phi$ STUD BOLT     |
| 5  | 6   | BOOM/MAST CLAMP        |
| 6  | 2   | U BOLT                 |
| 7  | 4   | 6 $\phi$ WASHER        |
| 8  | 4   | 6 $\phi$ SPRING WASHER |
| 9  | 4   | 6 $\phi$ NUT           |

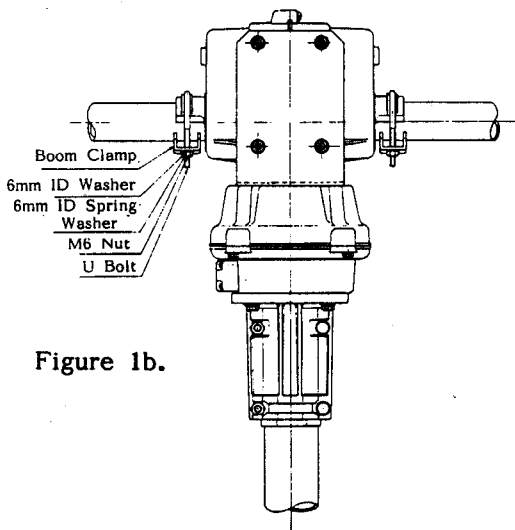
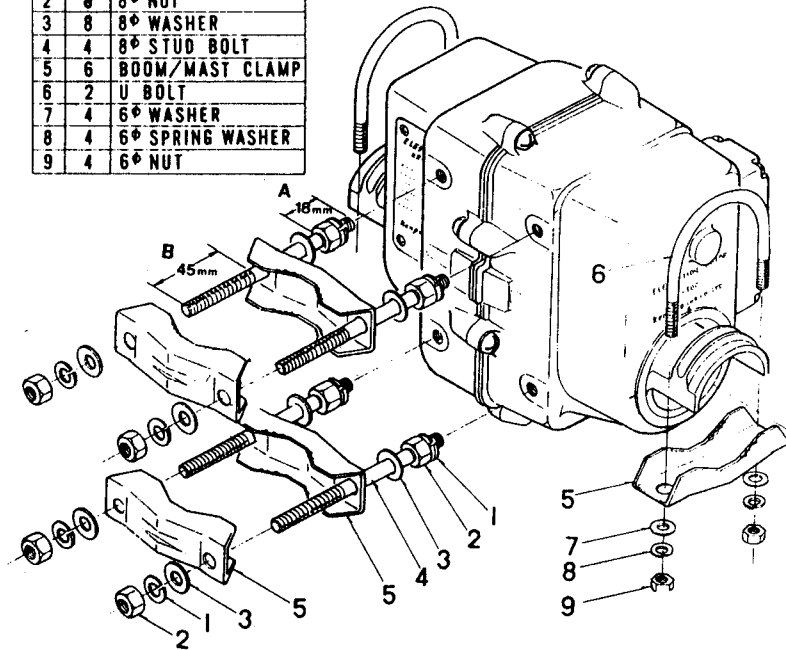

Figure 1b.

## Mast Bracket Attachment in the Azimuth Rotator, & Antenna Positioning

- (1) Loosely fasten the mast bracket halves (1) to the rotator housing using four short bolts, split washers and flat washers (2).
- (2) Insert the mast into the bracket, and finger-tighten the four longer bolts (3) with split washers, flat washers and nuts (4).
- (3) Set the controller so that it indicates precisely  $0^{\circ}$  (North). Then, using an accurate map and known landmarks, position the antenna (without using the controller) so that it points to true North. Alternatively, consult a Geodetic Survey map for your area to determine the Magnetic Deviation at your location, and then use a compass to position the antenna so that it points to true North (Magnetic North + Magnetic Deviation). Be careful not to disturb the antenna direction when tightening the mast bracket in the next step.
- (4) Referring to the mast gauge markings on the rotator housing, tap the mast bracket halves to center the mast while alternately tightening the short bolts (2) and nuts (4) on the long bolts alternately.

**CAUTION:** The azimuth rotator is designed for vertical mounting only. One half of the housing is marked "TOP SIDE". Water and contaminants will damage the motor unit if it is mounted horizontally or upside-down.

The rotator motors are rated for five-minutes intermittent duty. However, they can safely run continuously for as long as ten minutes providing that they be brought to rest for at least ten minutes afterwards.

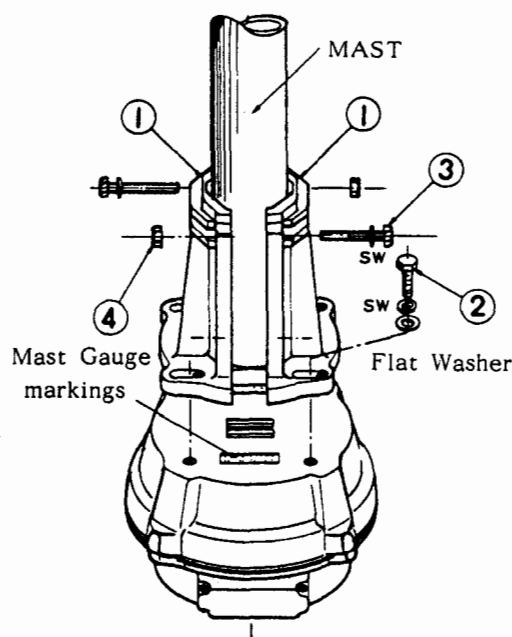

**Bracket Attachment for Tower Mounting**  
(for mounting together with elevation rotator outside of a tower, mount the bracket on the bottom of the azimuth rotator nearest the terminal box)



# G-5400B SCHEMATIC DIAGRAM

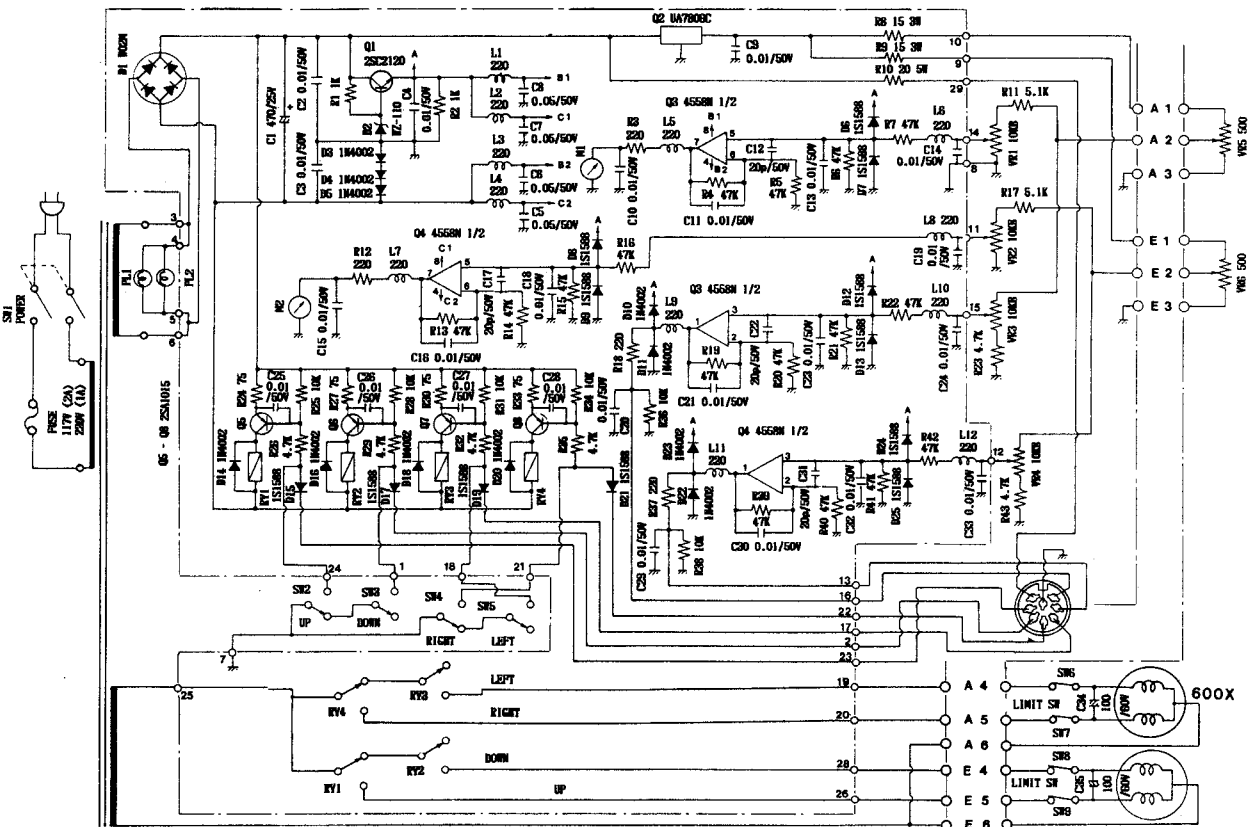
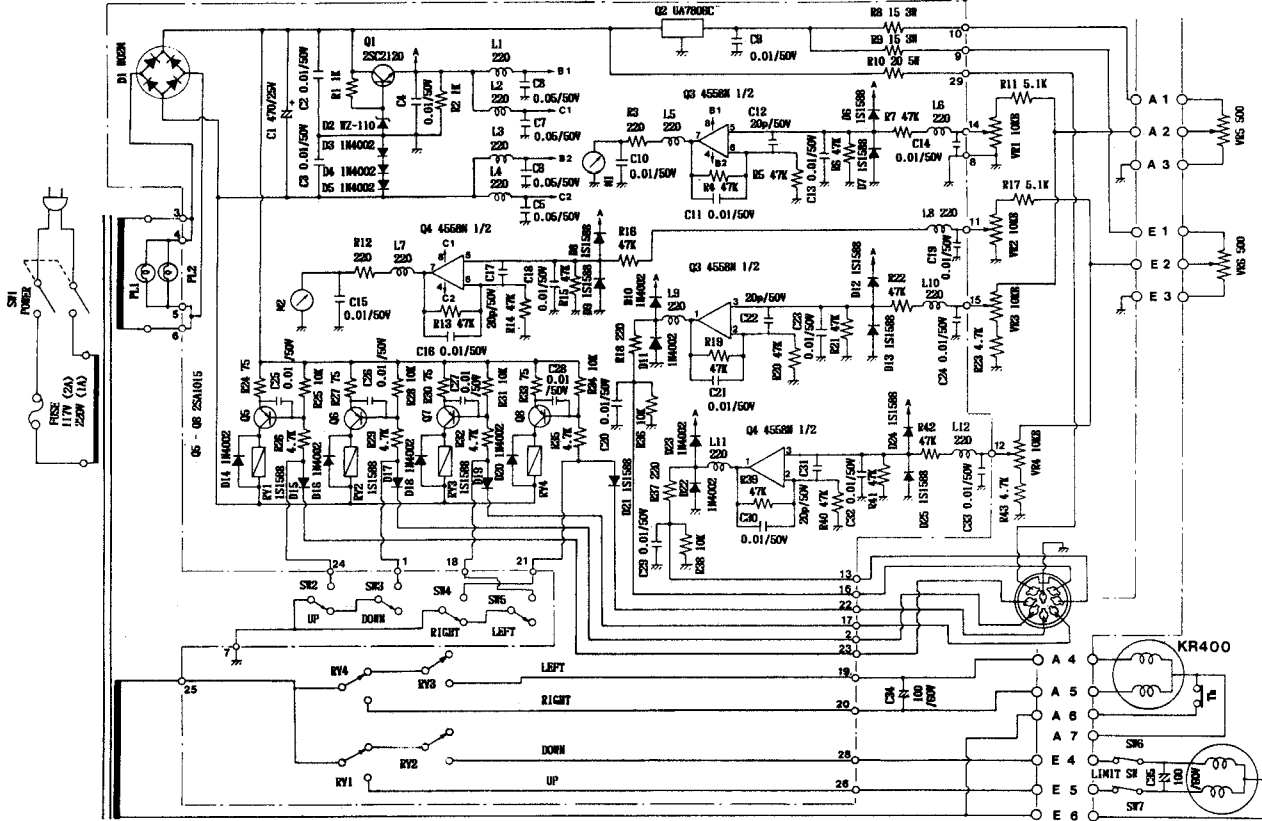

# G-5600B SCHEMATIC DIAGRAM

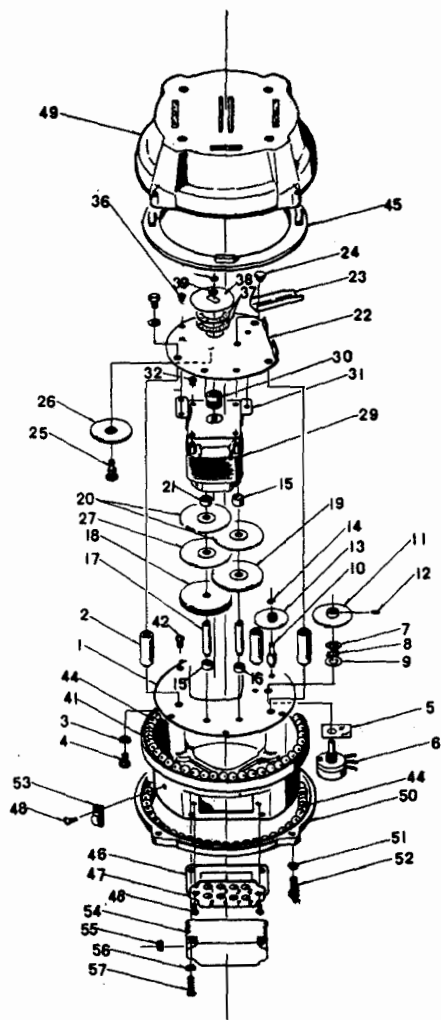
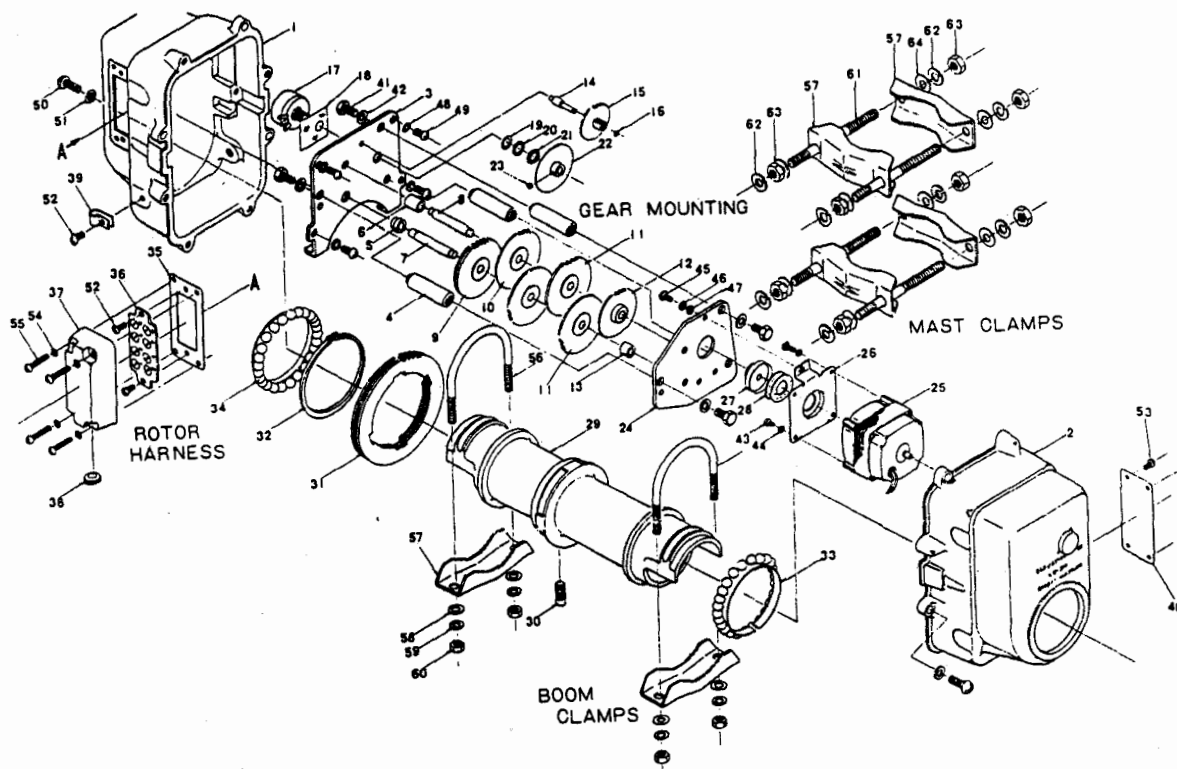

G-5400B

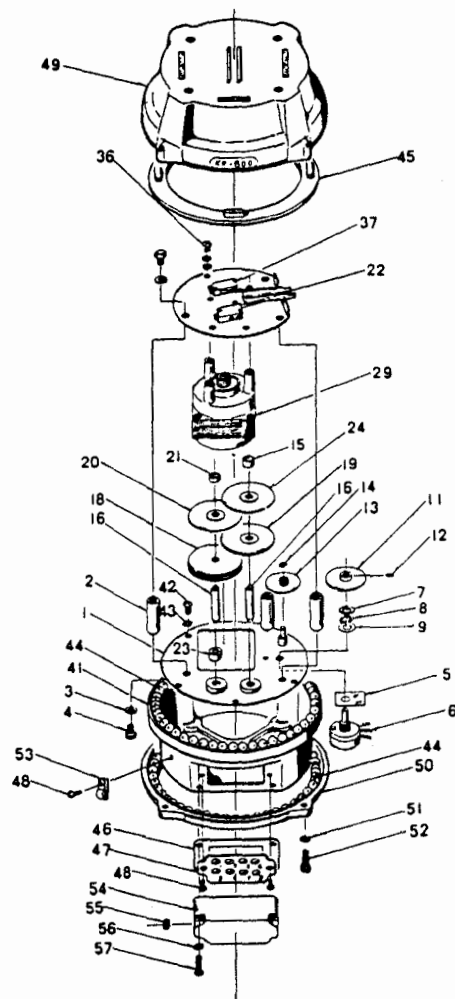

G-5600B

## PARTS LIST

### Elevation Rotator

- |                                   |  |  |
|-----------------------------------|--|--|
| (1),(2) Housing                   | (25) Motor (24VAC)                               | (43),(44) Motor Mount Screw and Washers (x4 each)  |
| (3) Gear Mount Plate              | (26) Motor Mount                                 | (45),(46),(47) Motor Support Screw & Washers       |
| (4) Gear Mount Support Stud (x3)  | (27) Disc Brake/Motor Pinion                     | (48),(49) Gear Plate Mounting Screw & Washers (x4) |
| (5) Gearshaft Bushing (#1)        | (28) Brake Pad                                   | (50),(51) Housing Screw & Washers (x6)             |
| (6) Gearshaft Bushing (#2)        | (29) Boom Tube                                   | (52) Terminal Ass'y/Cable Clamp Screw (x3)         |
| (7),(8) Gearshaft (x2)            | (30) Rotation Stopper Stud                       | (54),(55) Terminal Cover Screw & Washer (x4)       |
| (9) 2-pc Sandwich Gear            | (31) Boom Tube Sandwich Gear                     | (56) 'U' Bolt (x2)                                 |
| (10),(11) Transmission Gears (x4) | (32) 'C' Ring                                    | (57) Pipe Clamp Halve (x6)                         |
| (12) Plastic Motor Gear           | (33),(34) Bearing Ring                           | (61)-(64) Mast Clamp Ass'y Hdwe                    |
| (14) Pot Reduction Gearshaft      | (35) Terminal Gasket, Rubber                     |  |
| (15) Plastic Pot Reduction Gear   | (36) Terminal Ass'y                              |  |
| (17) Potentiometer                | (37) Terminal Cover                              |  |
| (18) Insulator Sheet              | (38) Ctrl Cable Grommet                          |  |
| (22) Pot Gear                     | (39) Cable Clamp                                 |  |
| (23) Pot Gear Setscrew            | (40) Nameplate                                   |  |
| (24) Gear Mnt Plate: Motor End    | (41),(42) Gear Mount Screw and Washers (x4 each) |  |

### Azimuth Rotator (G-5400B)

- |                                    |                               |                                       |
|------------------------------------|-------------------------------|---------------------------------------|
| (1) Gear Mounting Plate Ass'y      | (22) Gear/Motor Mount Plate   | (41) Lower Housing                    |
| (2) Gear Mount Support (x3)        | (23) Revolution Stopper       | (42) 5mm Gear Plate Screw (x6)        |
| (3) 6mm dia Washer (x3)            | (24) Stopper Mounting Pin     | (43) 5mm Gear Plate Washer (x6)       |
| (4) Gear Mount Screw (x3)          | (25) Pot.Gear Shaft #2        | (44) Ball Bearings                    |
| (5) Insulating Sheet               | (26) Plastic Pot. Gear        | (45) Internal Ring Gear               |
| (6) Potentiometer                  | (27) Spring Plate             | (46) Rubber Seal: Terminal Box        |
| (7) 9mm Pot. Shaft Nut             | (28) 3mm dia. E-Ring          | (47) Terminal Ass'y                   |
| (8) 9mm Pot. Shaft Lockwasher      | (29) Motor Ass'y              | (48) Terminal Ass'y/Cable Clamp Screw |
| (9) 9mm Pot. Shaft Flatwasher      | (30) Motor Pinion Gear        | (49) Upper Housing                    |
| (10) Pot. Gear Shaft #1            | (31) Motor Mount Plate        | (50) Housing Ring                     |
| (11) Pot. Divider Gear             | (32) 3mm Motor Mount Screw    | (51) 6mm Housing Washer               |
| (12) Pot. Div. Gear Setscrew       | (33) 3mm Motor Mnt Washer     | (52) Housing Screw                    |
| (13) Plastic Pot. Gear             | (34),(35),(56) 4mm Washers    | (53) Cable Clamp                      |
| (14) 2.5mm dia. E-Ring             | (36) 4mm Motor Mnt Screw (x3) | (54) Terminal Cover                   |
| (15),(16),(21) Stud Support Sleeve | (37) Brake Disk Pad           | (55) Rubber Grommet                   |
| (17) Gear Shaft (x2)               | (38) Brake Disk Plate         | (57) Terminal Cover Screw             |
| (18) Main Gear                     | (39) 3.5mm dia Flat Washer    |                                       |
| (19),(20) Pinion Gear Ass'y        | (40) 2.5mm dia E-Ring         |                                       |

### Azimuth Rotator (G-5600B)

- |                                |                                 |                                       |
|--------------------------------|---------------------------------|---------------------------------------|
| (1) Gear Mounting Plate Ass'y  | (15),(21) Stud Support Sleeve   | (45) Internal Ring Gear               |
| (2) Gear Mount Support (x3)    | (16) Gear Shaft (x2)            | (46) Rubber Seal: Terminal Box        |
| (3) 6mm dia Washer (x3)        | (18) Main Gear                  | (47) Terminal Ass'y                   |
| (4) Gear Mount Screw (x3)      | (19),(20) Pinion Gears          | (48) Terminal Ass'y/Cable Clamp Screw |
| (5) Insulating Sheet           | (22) Gear/Motor Mount           | (49) Upper Housing                    |
| (6) Potentiometer              | (29) Motor Ass'y                | (50) Housing Ring                     |
| (7) 9mm Pot. Shaft Nut         | (34),(35),(56) 4mm Washers      | (51) 6mm Housing Washer               |
| (8) 9mm Pot. Shaft Lock Washer | (36) 4mm Motor Mount Screw (x3) | (52) Housing Screw                    |
| (9) 9mm Pot. Shaft Flat Washer | (37) Rotation Limit Switch      | (53) Cable Clamp                      |
| (11) Pot. Divider Gear         | (41) Lower Housing              | (54) Terminal Cover                   |
| (12) Pot. Div. Gear Setscrew   | (42) 5mm Gear Plate Screw (x6)  | (55) Rubber Grommet                   |
| (13) Plastic Pot. Gear         | (43) 5mm Gear Plate Washer (x6) | (57) Terminal Cover Screw             |
| (14) 2.5mm dia. E-Ring         | (44) Ball Bearings              |                                       |